



**TRH**



**THE ERGT100 SERIES**

# ERGIT 100: A NEW TRACTOR CONCEPT

HYDROSTATIC  
REVERSIBLE

*Antonio Carraro SPA produces specialized tractors for professionals wishing to experience the emotion of owning something unique and precious that is guaranteed by a one-hundred-year-old brand at the cutting-edge of "Italian Style".*



The Ergit 100 series is a new tractor concept. It is the outcome of a construction philosophy based on engineering simplification and the selection of top quality components; factors that allow the company to give these models a 2-year warranty. The care taken in design assures a pleasant and relaxed driving experience. It is not only attractive, but also performance enhancing as it allows for total operator visibility in all directions and ease when working in small spaces. The engines, with power outputs from 70 to 100 hp, offer exceptional torque and power levels combined with lower fuel consumption. The bodywork is painted with environmentally-friendly hydrosoluble enamels. Each technical solution is the result of choices that are based on socio-environmental benefits in terms of reduced pollution and noise levels.



THE  
**ERGIT100**  
SERIES





## MULTI-FUNCTIONALITY: a tractor with unique features



The TRH is the “big” reversible hydrostatic tractor in the Antonio Carraro range. It has been designed to satisfy multiple requirements thanks to special technical features which it even more versatile, practical, comfortable and simple. The hydrostatic transmission, a key feature of the TRH, provides an infinitely variable speed in both forward and reverse. The integrated lifting-hydraulic system-PTO assembly allows an extensive range of implements to be mounted, both individually or combined. These include front or rear power shovels, snow plow and snow blower, fork lift, digger, lateral hedge arm, plow, sprayer, shredder, vertidrain, mower and catenary, as well as replanting equipment featuring micrometric speed variations.

TRH 9800 is also a top performer in haymaking and the maintenance of embankments and escarpments. Thanks to the lifting system with hydraulic suspension, the wide range of specific tires, the optional StarLight cab or EasyStar 6-upright chassis, TRH 9800 is the ideal tractor for the toughest and most demanding jobs, as it simplifies procedures and reduces working times.



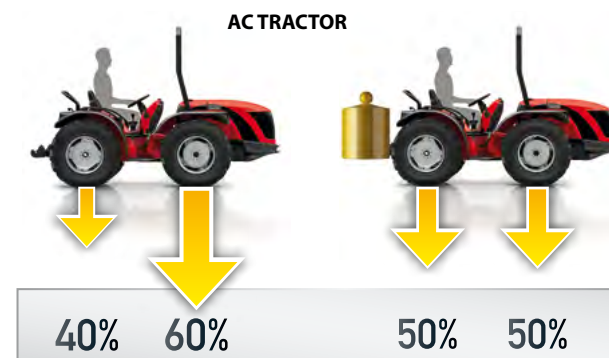
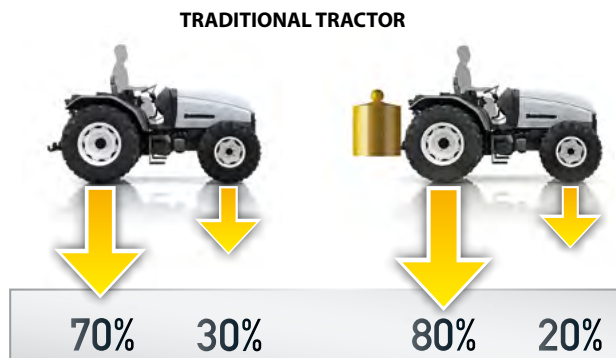

## ACTIO™: the exclusive chassis designed by Antonio Carraro

**ACTIO™**, This Full Chassis with Oscillation is comprised of a solid cast-iron chassis fixed to the axles and housing the tractor transmission. It features a central joint with a longitudinal oscillation of up to 15°. The two oscillating ends follow the contour of the terrain independently, thus assuring stability and traction at all times. The constant adherence of the tires to the ground allows engine power to be entirely transferred to the ground, thus increasing performance and safety. The ACTIO™ chassis requires a “projecting” engine configuration in order to assure a low center of gravity and an equal division of the weight of the tractor: 60% on the front axle; 40% on the rear axle. This is an ideal balance with implements attached as it distributes 50% of the weight on each axle.

**ACTIO™**



**PLUS**

- + **Stability:** low center of gravity with 4 wheel drive
- + **Safety:** peace of mind
- + **Comfort:** driving position centered over chassis oscillation
- + **Agility:** short wheelbase and reduced turning radius
- + **Adherence:** equal division of weight
- + **Traction:** 4 drive wheels always firmly in contact with the ground

# RGS™: two sides of the same coin

VERSATILITY  
CREATIVITY  
SAVING

## RGS™

**RGS™ Rev-Guide System**, is the AC reversible driving system on a rotating turret which inverts the driving direction in just a few seconds in order to work efficiently with towed or frontal equipment. Simply turn the seat/steering wheel/dash/pedal assembly 180° for an identical, but reverse, driving direction. If equipped with a Joystick\*, all the auxiliary controls remain in an ergonomic position. The RGS™ system is an integral part of the tractor's multifunctional feature. It simplifies use and improves the precision and quality of performance.

PLUS

- + **Comfort:** simple and intuitive RGS™ system without double controls
- + **Visibility of equipment:** driving position in the center of the vehicle, in both directions
- + **Versatility:** greater profitability of tractor



\*optional

# ERGONOMICS & COMFORT

The tapered and racy design helps the tractor to maneuver in fields and increases operator visibility of the equipment and the surrounding terrain. The spacious driving position is easy to access and protects the operator. The operating station is suspended on **silent-block**, which absorb vibrations and dampen noise. Thanks to the ACTIO™ Chassis, the driving position coincides with the center of oscillation of the tractor.



Sideways jerking and stress are very limited and operator fatigue is reduced, even after many hours. The on-board instrumentation is elegant, functional and intuitive: backlit anti-reflection screen for nighttime use; "on-off" information system; digital tachometer and PTO rev counter; and electro-hydraulic pushbutton controls.



The lighting equipment, integrated into the mudguards, is comprised of reflecting parabolic optical assemblies, which offer a wide range of illumination covering the roadway, the equipment, and the surrounding field. Maintenance is practical and fast thanks to the fact that the bonnet can be fully opened and the side panels and battery cover can be easily removed.

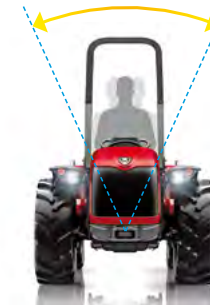

AC TRACTOR



TRADITIONAL TRACTOR

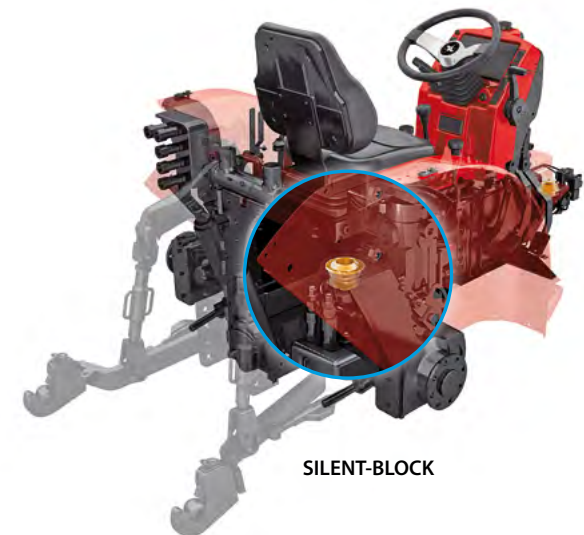

SILENT-BLOCK

# STEERING: precise and tight

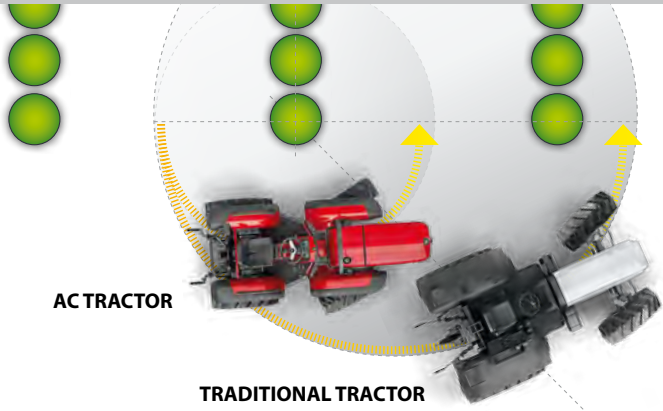

The short wheelbase and tight steering radius make the tractor extremely agile in crop rows. To further reduce the turning radius, the steering brakes can be utilized, while accentuating the “superbend” effect obtained thanks to the double-acting constant velocity joints. The front wheel on the inside of the curve naturally increases the steering angle without the vehicle being allowed to stick. The smooth and sensitive hydroguide steering wheel assures precise maneuvering on steep slopes, in crossways movements, in narrow paths, among crop rows and in car parks. The hydraulic hydroguide system is independent; powered by its own hydraulic pump and fitted with an oil-filtering system.



**AGILITY  
PRECISION  
SPEED**



Low center of gravity, constant contact, stability, protected driving position: are just some of the “active” safety features of TRH, as well as the “passive” features, such as: quality of components, design, and eco-friendly engines. The braking system is comprised of 4 hydraulically controlled, disc brakes in an oil bath which assures emergency braking modularity and reliability even when the front axle is disengaged. The rear three-point lift features controlled position and force of the implement, which optimizes adherence of the tractor, such that it always stays “glued to the ground”. The electrohydraulically controlled differentials lock at the rear and the front in order to prevent slippage and assure that the tractor tires always have traction. The driving position features a roll-bar, a StarLight cab or a EasyStar chassis. All are approved to safety standards, to ensure maximum operator protection.

AC TRACTOR



TRADITIONAL TRACTOR

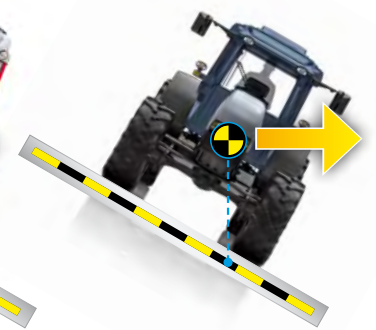

# SAFETY: active and passive

# MACHINE AND EQUIPMENT: an integrated technological system

**VERSATILITY  
CREATIVITY  
SAVING**

The integrated lifting - hydraulic system - PTO assembly can mount a large variety of implements at both the front and rear. The lift is a single group with vertical cylinders, featuring a 3-point hitch, a pump, and an independent hydraulic system. The rear electronic\* lift, featuring draft and position control, controls the equipment precisely and optimizes the stability of the tractor allowing it to follow the contour of the terrain without slipping or sliding sideways.

The front lift\* optimizes combined processes such as a front grass shredder with a rear between-row mower, a front vine trimmer with a rear side-shoot remover, a front vine trimmer with a rear mulcher, or a front snow blade with a rear salt/sand spreader. The clutch of the PTO with an electro-hydraulic progressive engagement command features a safety button for preventing involuntary starting and stopping the engine with the PTO engaged.

\*optional



- + **Practicality:** engagement facilitated by the cardan shaft
- + **2 Speeds:** fuel saving
- + **Comfort:** the PTO can be engaged while the tractor is moving
- + **Efficiency:** less heat build-up
- + **Multifunctionality:** hydraulic engines run at a constant speed
- + **Functionality:** engagement without stalling the engine
- + **Lifetime:** safeguard of PTO shaft
- + **Comfort:** less operator stress





Vertical hydraulic tie-rod and 3-point hitch\* allow adjustments to be made from the driver's seat.



The slider\* tow hook with rapid vertical adjustment, is used to optimize the connection height of the towed equipment.



Two speed PTO: 540 rpm, 540 E (750 rpm) and synchronized with gear speeds. The PTO shaft of the ASAE 1 3/8 type is the same for all speeds.



Hydraulic system with 3 manifolds: 1 double-acting, 1 double-acting with floating position and stop lever, 1 single-acting + oil return tap. Total: 6 rear quick-couplers.



The front lift\* optimizes work combined with rear tools.



The rear differential lock prevents slipping and optimizes traction. The front traction disengagement is useful when travelling along roads and prevents damage from being done to delicate grounds.



\*optional

# CAB: "Starlight"

This original and approved AC product features a spherically curved, simple and essential design. The airtight seals and integrated hinges allow the "Starlight"\* cabin to enter the narrowest rows without damaging flowering plants or fruit. The front and rear windows offer full visibility of equipment and the roadway. The ventilation system features a rapid front windscreen defogging system.

The acoustic comfort on board the "Starlight" is similar to that of a car due to the internal layer of sound-absorbing material on the cabin walls. "Starlight" features a car radio, a removable license-plate holder, and adjustable rear-view mirrors.



The forced ventilation of the air-conditioning system generates an internal pressurization effect. The incoming air is cleaned by a large filter, with an available activated carbon filter.

The panoramic roof with sunblind and full glass doors offer full top and side visibility.

The air-conditioning is achieved by a powerful system running on R134A ecological coolant, which also refreshes the cabin air using a low rev motor. The heating system utilizes a powerful heat-exchanger which is most exceptional even in the coldest weather.

Cabin controls (windshield wipers, work lights, rotating beacon) in an ergonomic position, even when reversing.

Easy access to the driving position with all-around visibility.

\*Optional

COMFORT  
VISIBILITY  
SAFETY

# CHASSIS: "EasyStar"

The "EasyStar"\* chassis was designed to assure comfort, ergonomics, safety, working space and visibility of equipment even when reversing. The basic configuration, which protects the operator from bad weather and sunshine, features a 6-upright chassis with protective roof including a left-hand rear view mirror, license-plate holder, rotating beacon connection and connections for rear and front work lights. Customers can purchase further accessories to complete the basis chassis, such as front and rear windshields complete with wipers, washer fluid and right-hand rear view mirror. Operators can therefore work even in pouring rain and in the toughest conditions.



\*Optional



# HYDROSTATIC TRANSMISSION: many more advantages

Thanks to the **ESC (Electronic Speed Control)** device, the TRH is a specialist for work requiring constant forwards speed and/or constant PTO revolutions, such as when using sanders, planters or sprayers. This device memorises and modulates tractor speed and can be activated at the discretion of the operator who can also set the revs of the power take-off and select the forward speed. The saved settings will remain constant until the job is done.

The TRH is equipped with a hydrostatic gearbox which allows 4 different speed ranges to be used: 2 working speeds (0-10 and 0-20 Km/h) and 2 road speeds (0-30 and 0-40 Km/h).

As the clutch pedal is not required, operators enjoy a very relaxed jerk-free driving experience which is particularly appreciated wherever rapid forward and reverse movements are needed. The hydrostatic transmission makes it easy and practical to change the running direction by shifting the direction reverser lever located under the steering wheel forwards and backwards.

Movement in an opposite direction will be progressive at every speed, without using the clutch pedal.

When the manual accelerator lever is in the "zero" position, the AutomotiveEco-Power device is automatically enabled. This device sets the number of engine revs according to vehicle speed using the right power level and without wasting fuel.

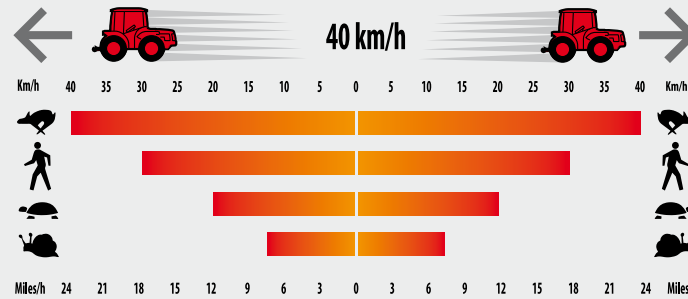

- + **Reliability:** long lifetime of the clutch
- + **Efficiency:** wide range of speeds
- + **Comfort:** smooth engagement without jerking the engine
- + **Saving:** lower fuel consumption and reduced running costs



## ENGINE: powerful and quiet

The engines are at the top of their category and offer unbeatable torque and power performance as well as lower fuel consumption, lower noise, and lower carbon emissions. All the engines comply with "STAGE 3A" standards which limit the harmful emissions of diesel engines. Intercoolers, turbos, electronic EGR's, and multivalves, are utilized depending on the model of tractor. Thanks to this new generation of engines, the company has achieved new goals in terms of efficiency and cost-effectiveness.



- + **Reliability:** quality of components
- + **Performance:** maximum efficiency
- + **Comfort:** minimum vibrations, noise, and emissions
- + **Saving:**
  - € less maintenance costs
  - € rapid amortisation
  - € lower fuel consumption

# ELECTRO-HYDRAULIC JOYSTICK: all functions at your fingertips

The **ON/OFF JOYSTICK\*** allows practical operation of the lift and the front and rear hydraulic quick-couplers. It is compatible with the standard controls of the draft and position control. The operator adjusts all the hydraulic functions including the lifting speed. The draft control assures maximum stability of plowing equipment and load handling, which results in maximum productivity.



- + *Ergonomic*: handy to use
- + *Comfort*: stress-free operation
- + *Saving*: reduction in cycle times



The **JPM PROPORTIONAL JOYSTICK™\*** allows practical operation of the lift and the front and rear hydraulic quick-couplers. It also adjusts the oil flow towards the hydraulic connectors and lift, thus assuring total control of speed and movements of the attached implement. A hydraulic quick-coupler constant flow adjuster controls the operation and speed of the hydraulic motors and at the same time, controls implement hydraulic movements. A descent adjuster controls the implement lowering speed without interfering with lifting speed. An external switch simplifies attaching of the implement.

The **“hydropneumatic” suspension** (transferring the weight of the equipment to the tractor tires) optimizes the distribution of the weight of the tractor and equipment on all 4 wheels, as determined by the ACTIO™ chassis. It also keeps the weight of the equipment constant on the ground, regardless of the gradient, the difficulty of the terrain and the forward speed.



**HARMONY  
TECHNOLOGY  
PROGRESS**

\*optional

# OPTIONAL



## **BULLBAR**

Tubular steel guard protecting the bodywork; integrates the third-point for the front lift.



## **FRONT LIFT**

Used together with the bullbar, it allows all the frontal equipment to be used with multiple hydraulic connectors.



## **FRONT BALLAST**

Perfectly integrated into the bodywork of the tractor; it does not alter the wheelbase or dimensions of the tractor.



## **HEADLIGHT GRILLES**

Protecting the light assemblies, they also make the bodywork look more appealing.



## **SLIDER HOOK**

Integrated into the rear lift, it gives the operator various options for the practical setting up of the tractor and the rapid alignment of the towed equipment.



## **VERTICAL TIE-ROD AND HYDRAULIC THIRD-POINT**

Optimizes the positioning and inclination of the equipment.



## **RAPID REAR COUPLINGS**

On/off joystick > 6 rear couplings.  
JPM joystick > 6 rear couplings + 1 connector with constant flow and oil flow adjuster.  
Vertical tie-rods + hydraulic third hitch > 4 rear independent mini couplings.

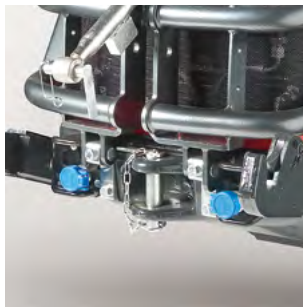

## **QUICK COUPLERS**

Front lift > 6 rear couplings + 2 replicated.

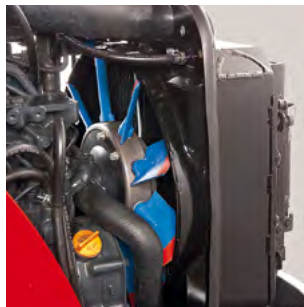

## **CLEAN FIX™ system**

Reverse flow fan that assures the constant cleaning and efficiency of the radiator and of the front grille of the bonnet.



## **REAR CAST IRON WHEEL FLANGES**

Flanges that increase the weight of the tractor at the rear.

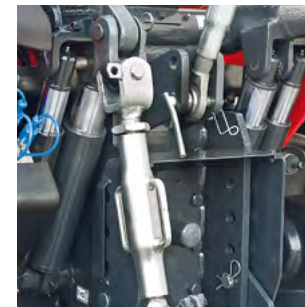

## **HYDRAULIC SUSPENSION**

Rear lift with hydraulic suspension (2+2 cylinders).



## **PNEUMATIC SEAT**

Latest generation air-suspension seat.

# TECHNICAL DATA: TRH



<b>Model</b>	<b>TRH 9800</b>	
<b>Chassis</b>	"ACTIO™" – Full chassis with oscillation • Reversibility RGS™ • Steering wheels • 4 equal wheel drive • Front and rear final drive	
<b>Engine Type</b>	Diesel direct injection with counter rotating weight system	
	Emissions Regulations: Stage 3A	N° Cylinders: 4 - 16 Valves • Turbo
	Displacement (CC): 3319	Power kW/HP (97/68/CE): 64/87
	Maximum engine revs: 2500	Torque max (Nm/revs): 286,7/1850
	Cooling: Water	Tank Capacity (litres/gal): 60/15.85
<b>Transmission</b>	Hydrostatic – Continual variation of forward speeds in both drive direction from 0>40 Km/h with a mechanical selector of the 4 speed variator – Electrohydraulic reverser under the steering wheel – ESC (Electronic Speed Control) Electronic and automatic speed and engine rev control device – "Automotive Eco-Power" device	
<b>PTO</b>	Rear, independent and synchronized at 540/540E rpm with progressive electrohydraulic engagement	
Shaft	Profile 1" 3/8 with 6 splines with facilitated engagement	
<b>Transmission clutch</b>	Hydraulic control	
<b>Drive disengagement</b>	Electrohydraulic control on the front	
<b>Rear hydraulic lift</b>	Draft and position control with 3 point hitch	
Operating Pressure (bar/psi)	160/2320	
Capacity (Kg/lbs)	2400/5291	
<b>Steering</b>	Hydraulic with 2 pistons	
<b>Brakes</b>	Standard: hydraulic front and rear disk brakes in oil bath, rear steering brakes Independent emergency and parking brake: band type on transmission	
<b>Platform</b>	Suspended on Silent Block	
<b>Weight</b> in order of speed:		
With roll bar (Kg/lbs)	2205÷2315 / 4861÷5104	
With chassis (Kg/lbs)	2275÷2385 / 5015÷5258	
With cab (Kg/lbs)	2365÷2475 / 5214÷5456	

## Standard Features

- Reversible driving position with servo-assisted reversibility
- Rear or front/rear differential lock with electrohydraulic control
- Hydraulic system with 2 separate hydraulic pumps
- Adjustable steering wheel
- Lifting arms with quick release couplings
- Adjustable, suspension seat with safety belt
- Foldable protection roll bar
- Adjustable wheel rims
- 3 lever ancillary rear hydraulic system
- Rear adjustable height tow hitch
- Front tow hitch
- Multifunctional digital instrument Km/h and PTO
- Battery
- Electrical power point
- Safety starting device on the inverter and PTO

## Optional

- Star Light cab with air conditioning system and window on the roof, suspended on Silent Blocks
- EasyStar safety chassis with 6 uprights, fitted on Silent-block, with roof and left rear view mirror, (optional) front and rear windscreens complete with wipers and right rear view mirror
- Lift and hydraulic quick couplers controlled by "ON/OFF" or "Proportional" Joystick
- Lift controlled by "ON/OFF" Joystick with hydraulic suspension (2+2 cylinders)
- Support with six front ballast weights
- Hydraulic third hitch and vertical tie-rod with electro-hydraulic control
- Front power lift
- Gearbox with PTO 540-1000 rpm
- Up to five types of front hydraulic system with a maximum of 11 hydraulic quick couplers
- Adjustable lifting arms with quick release couplings
- Pneumatic seat
- Slider tow hitch
- Pair of front/rear ballasts
- Cast iron wheel flanges for 20" rear wheels
- Front bullbar
- Front lamp guards
- Clean FIX™ > reverse flow fan for constant cleaning of the radiator and of the front grille of the bonnet



# DIMENSIONS TRH

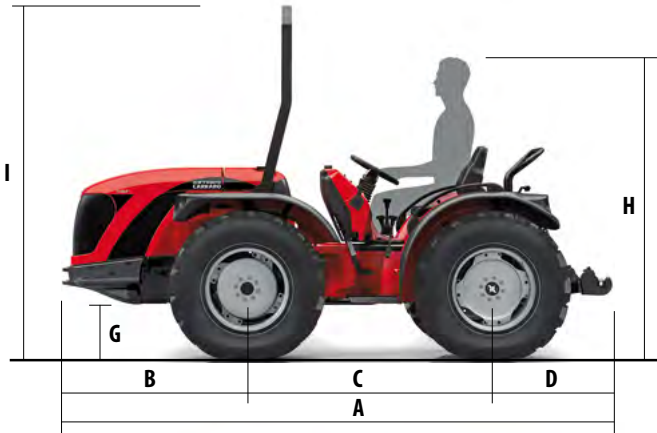

<b>250/80 R18</b>	<b>280/70 R18</b>	<b>9.5 R20</b>	<b>300/70 R20</b>	<b>320/70 R20</b>	<b>300/80-15.3</b>	<b>320/65 R18</b>
<b>E 250</b>	<b>280</b>	<b>245</b>	<b>300</b>	<b>320</b>	<b>300</b>	<b>320</b>

<b>400/55-17.5 Terra Twin</b>	<b>31x15.50-15 Terra</b>	<b>31x15.50-15 Softrac</b>	<b>280/85 R20</b>	<b>450/55-17</b>
<b>E 400</b>	<b>395</b>	<b>395</b>	<b>280</b>	<b>450</b>

## Wheels

## Dimensions (mm/inch)

Front	Rear	A	B	C	D	F	G	H**	I	L*	M	N*	O	P
<b>250/80-18</b>	<b>250/80-18</b>	3505/138.0	1190/46.8	1505/59.2	720/28.3	2135/84.0	275/10.8	1802/70.9	2320/91.3	1380/54.3	1130/44.5	1350/53.1	1100/43.3	2065/81.3
<b>280/70 R18</b>	<b>280/70 R18</b>	3505/138.0	1190/46.8	1505/59.2	720/28.3	2135/84.0	275/10.8	1802/70.9	2320/91.3	1420/55.9	1140/44.8	1410/55.5	1130/44.5	2065/81.3
<b>9.5 R20</b>	<b>9.5 R20</b>	3505/138.0	1190/46.8	1505/59.2	720/28.3	2170/85.4	310/12.2	1832/72.1	2355/92.7	1390/54.7	1145/45.0	1390/54.7	1145/45.0	2100/82.7
<b>300/70 R20</b>	<b>300/70 R20</b>	3505/138.0	1190/46.8	1505/59.2	720/28.3	2170/85.4	310/12.2	1837/72.2	2355/92.7	1410/55.5	1115/43.9	1410/55.5	1115/43.9	2100/82.7
<b>320/70 R20</b>	<b>320/70 R20</b>	3505/138.0	1190/46.8	1505/59.2	720/28.3	2195/86.4	335/13.2	1857/73.1	2380/93.7	1460/57.4	1140/44.8	1435/56.5	1115/43.9	2125/83.7
<b>300/80-15.3</b>	<b>300/80-15.3</b>	3505/138.0	1190/46.8	1505/59.2	720/28.3	2135/84.0	275/10.8	1802/70.9	2320/91.3	1445/56.9	1145/45.0	1440/44.9	1140/44.8	2065/81.3
<b>320/65 R18</b>	<b>320/65 R18</b>	3505/138.0	1190/46.8	1505/59.2	720/28.3	2135/84.0	275/10.8	1802/70.9	2320/91.3	1460/57.4	1140/44.8	1450/57.1	1130/44.5	2065/81.3
<b>400/55-17.5</b>	<b>400/55-17.5</b>	3505/138.0	1190/46.8	1505/59.2	720/28.3	2120/83.4	260/10.2	1792/70.5	2305/90.7	1690/66.5	1290/50.8	1690/66.5	1290/50.8	2125/83.7
<b>31x15.50-15</b>	<b>31x15.50-15</b>	505/138.0	1190/46.8	1505/59.2	720/28.3	2100/82.7	240/9.4	1757/69.2	2285/89.9	1690/66.5	1295/51.0	1690/66.5	1295/51.0	2030/79.9
<b>280/85 R20</b>	<b>280/85 R20</b>	3505/138.0	1190/46.8	1505/59.2	720/28.3	2225/87.6	335/13.2	1857/73.1	2380/93.7	1410/55.5	1115/43.9	1410/55.5	1115/43.9	2100/82.7
<b>450/55-17</b>	<b>450/55-17</b>	3505/138.0	1190/46.8	1505/59.2	720/28.3	2180/85.2	290/11.4	1852/72.9	-	1760/69.3	1320/51.9	1760/69.3	1320/51.9	2080/81.9

\*Min. external width

\*\*Height calculated with the operator of average height sitting (cm/in 175/68.9)

# SAT: Customer Service Team



RICAMBI ORIGINALI  
GENUINE SPARE PARTS

## Antonio Carraro® Original Spare Parts and Assistance

The AC dealer network utilizes modern equipment and instruments that have been especially designed and built for maintenance work on AC tractors. The technicians at every authorized dealership periodically attend technical training courses at the Parent Company's facilities. Each authorized workshop employs highly qualified staff and provides an extensive range of services in order to offer its Customers maximum peace of mind and total protection. AC dealers can give their Customers information on all the services related to the care of AC tractors.



### 24 months of warranty

The experience gained during the years and the investments made in terms of materials and human resources have allowed Antonio Carraro to design and market the Ergit 100 Series with a standard 24 month warranty for the end customer. Customer satisfaction and safety is what counts most for Antonio Carraro. 24 months means giving Customers greater trust in what they have purchased and the certainty that they can count on a constantly available and highly qualified assistance service. A net of authorized centers assure efficient and professional maintenance on tractors.

### After-sales service

Thanks to the capillary network of dealers and the competence of the Service Managers, the Parent Company can assure all-around skills. With the right maintenance work, every AC tractor will continue to provide excellent performance throughout its operating lifetime.



### Original Antonio Carraro Spare Parts

Original Antonio Carraro Spare Parts is a registered trademark. The elevated standards of design and the stringent tests carried out during the entire production process assure maximum quality levels. With Original AC Spare Parts, Customers can be certain of maintaining tractor performance unaltered over time, thus preserving the safety and the value of the tractor.



**ANTONIO CARRARO SPA**  
Via Caltana, 24  
35011 Campodarsego Padova ITALY  
info@antoniocarraro.it  
antoniocarraro.com

COD. 4 7318 135 - 06/2012